

# HOT - LED oven lamp, Spot

77.115 · LED oven lamp with light conducting glass rod for round cutouts  $\varnothing$  11 mm

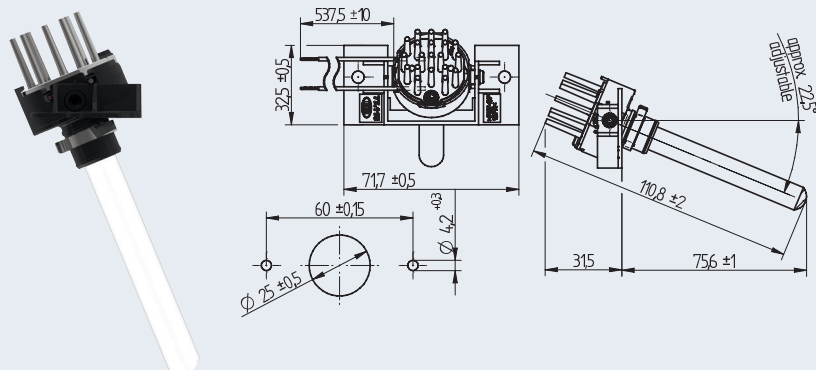

pkg. 54      wt. 43 g      part no. 77.115.2001.10

## Tiltable LED oven lamp with light conducting glass rod

Symmetrical light characteristic

Screw fixing: for M3 screws  
alternatively: push in fixing by using the P2F fixing element 28.905

- Due to the variable length of the light conducting glass rod, different installation heights in the oven are possible.
- Variable LED parameters (CCT, CRI, number) are possible
- Protection class III due to operation on SELV voltage
- Max. possible current of the lamp is to be determined in the most unfavorable operating condition
- The choice of our products, as well as the technically correct installation according to the relevant regulations (e.g. IEC 62031 and IEC60335), are the sole responsibility of the user.

Special versions with higher requirements such as steam tightness, with microwave shielding or pyrolysis suitability on request.

Photometric data	
Number of LEDs	1
Luminous flux @Ta25° C @ If typical	190 lm
Color temperature	3.500 K
Color rendering index (CRI)	> 80
Temperature data	
Max. temperature @ Tc-point of heat sink	110° C
Electrical data	
Operating mode	Constant current
Operating current If	1.000 mA
Output	3.0 W
Dimmable	yes, with suitable ballast
Material specifications	
Heat sink	Aluminum, anodized
Housing	PET
Light conducting glass rod	Borosilicate glass
Average life time (L70 / B50)	5.000 h (according to BJB test requirements)

Tolerances of optical and electrical data:  $\pm 10$  %.

## Installation position

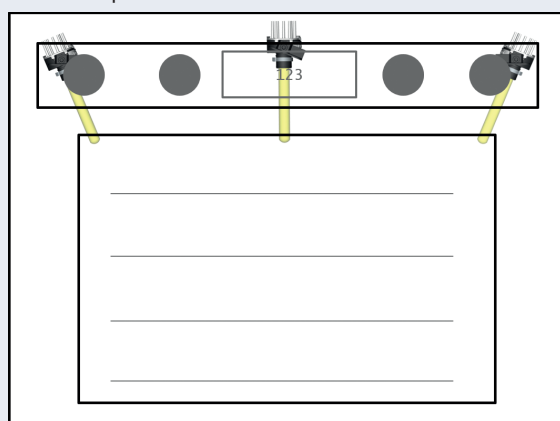

## **EOS/ESD safety guidelines**

Some components of the BJB /// OEM – Line Modular System might be harmed by electrostatic discharge (ESD) and electrical overstress (EOS) and may only be installed in the factory and on site if appropriate EOS/ESD protection measures have been taken.

Modules where no contact to the LED module is possible do not need special measures for protection of electrostatic discharge (ESD).

## **Assembly instructions**

The LED module may be exposed to tensile or compressive stresses.

## **Note to chemical reactions**

Chemical substances may harm the LED module. This could lead to reduced luminous flux, colour shift or total failure of the module caused by corrosion of electrical connections. Avoid corrosive atmosphere during usage and storage.

## **Life span and lumen maintenance**

The light output of an LED module decreases over the life-time, this is characterized with the L value.

L70 means that the LED module will give 70 % of its initial luminous flux. This value is always related to the number of operation hours and therefore defines the lifetime of an LED module. As the L value is a statistical value and the lumen maintenance may vary over the delivered LED modules.

## **Thermal design, tc point, ambient temperature and life-time**

The rated life of a LED module depends to a large extent on the temperature. If the permissible temperature limits are exceeded, the life of the LED module will be greatly reduced or the module may be destroyed.

The temperature at tc reference point is crucial for the light output and life-time of a LED module.

## **Electrical supply**

- The LED modules have no special protection against overvoltage, overcurrent, overload or short-circuit currents.
- To ensure reliable and safe operation a converter must be used which corresponds to the relevant regulations
- The BJB LED modules can be operated on SELV converters.
- The use of converters that provide constant voltage, permanent damage may occur.
- Wrong polarity may cause damage to the BJB LED components..