

OptiSquare 2x2 - IESNA Type 3 Medium

35.104 · 2x2 · Optics for Street and area lighting

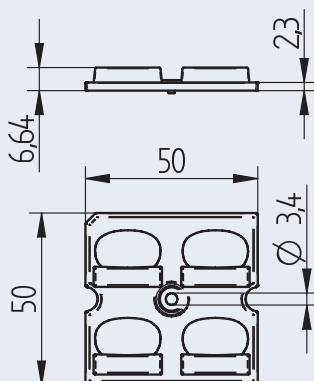
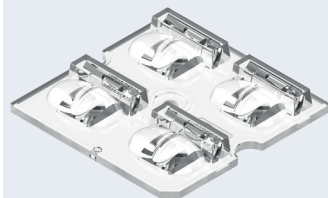

pkg. wt. part no.
120 9.4 g 35.104.1017.85

OptiSquare 2x2 - IESNA Type 3 Medium
Optics for Street and area lighting
for use with LED modules according to Zhaga Book 15

Light distribution: IESNA Type 3 Medium

Material: PMMA (clear)
Screw fixing: for screws M3
Maximum torque: 0.5 Nm

Suitable for Philips Fortimo FastFlex LED 2x6 / 740 DA HE and LED modules with 25.4 mm pitch distance according to Zhaga Book 15

Typical application:

- Walkways, paths and sidewalks
- Entrance roadways
- Loading and access ramps
- General road and street lighting
- Car parks and parking area lighting
- Perimeter of parking areas
- Center of roadways and intersections

Height	6.64 mm
Width	50 mm
Length	50 mm
Type of fixing	Screw fixing: (0.5 Nm) screws M3
LED Typep	Philips Fortimo FastFlex LED 2x6 / 740 DA HE and LED modules with 25.4 mm pitch distance according to Zhaga Book 15
Pitch distance	25.4 mm
Material	PMMA
Colour	clear
Lens surface	High gloss
Permissible application temperature	-40 °C bis + 75 °C

The presented information are for reference only. All lighting parameters are typical values.
The light distribution depends on the used type of LEDs, position tolerance, chip size and used colour.

-40°C
+75°C

CAD

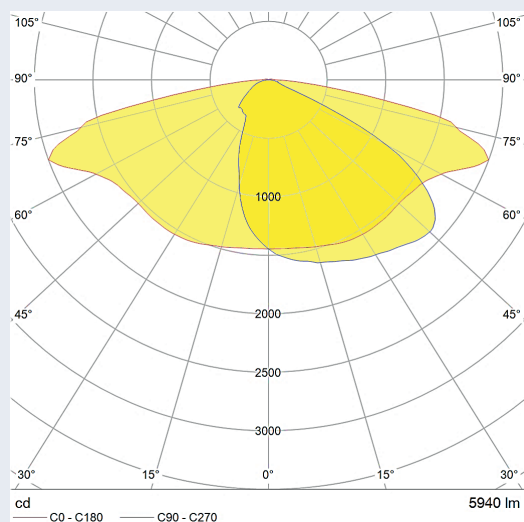

Light distribution: IESNA Type 3 Medium
measured with Philips Fortimo FastFlex LED 2x6 / 740 DA HE

Efficiency: 95%