

COB Connector Slim

47.360 COB Connector Slim Ø44 LED array 19 x 19

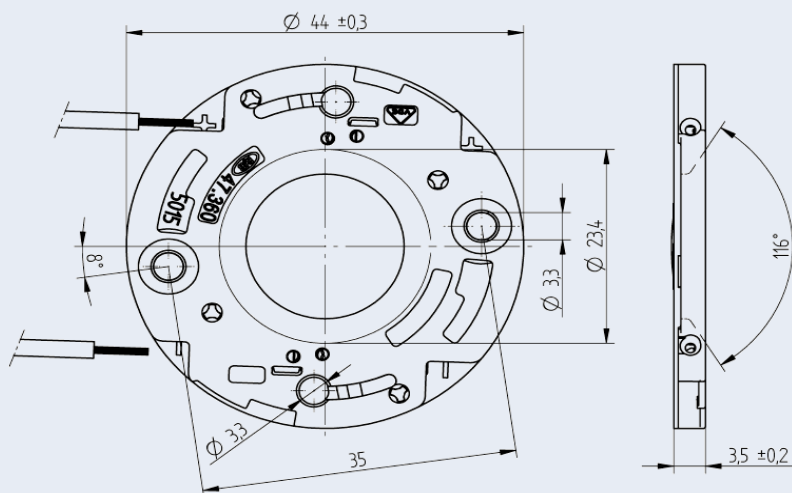

technology for light



Part no.

47.360.5015-0

- Compact Design
- High-Strength Housing
- Durable Contacts
- Flexible Connectivity
- COB Pre-fixation
- Accessory Integration
- Clear Markings

Polarity of LED must be observed
Specifications of LED manufacturer must be observed
cURus: For limited applications

Mechanical data		
Screw fixing	M 3	
Max. torque	0.5 Nm	
Alternative with P2F for blind holes	28.902.E102-0	
Integrated interface for reflectors	Yes	
Material data		
Material housing and cover	PBT	
Material contacts	CuSn	
Weight	4.22 g	
Electrical data		
	VDE (EN60838-1)	UL (UL 8754)
Current rating	3 A	3 A
Voltage rating	150 Vdc	60 Vdc
Connection data		
Connection technology	push-in terminals	
Solid wires	0.35 - 0,5 mm ²	AWG 22 - 20
Stranded , tinned wires	0.35 - 0.5 mm ²	AWG 22 - 20
	max. 1.05 mm	
Strip length	8 +1 mm	
Country specific certificates		
VDE certificate	40047483	
UL file number	E345385	
Commercial data		
Packaging quantity	540	
Weight	3 g	
Environmental requirements		
Operating temperatur range	-30 to +110°C	

Specification of LED manufacturer must be observed

In a series connection of LED modules, the air gap and creepage distances has to be sized that each modules cover the total voltage of the series connection

COB compatibility list see BJB website
<https://www.bjb.com/>

*Warranty conditions of BJB GmbH & Co. KG as stated as available via the Internet under
<https://www.bjb.com/en/legal-information/general-terms-and-conditions/> are valid.

COB Holder - Gen.2 47.360

Slim COB Holder



technology for light

BJB Spotlight connection elements bring the components of an LED light engine together.

The Slim Gen 2 COB holder is engineered for exceptional durability, flexibility, and a straightforward, safe assembly process.

- **Compact Design:** At only 3.5mm (9/64 in) high, this holder helps minimize the overall height of a luminaire, making it ideal for sleek, low-profile lighting solutions.
- **High-Strength Housing:** Constructed from a high-strength Polybutylene Terephthalate (PBT) thermoplastic material, the housing offers excellent blue-light resistance, ensuring a long lifespan. The PBT mix also provides a highly reflective surface, enhancing the light engine's efficiency.
- **Durable Contacts:** The copper-tin (Cu-Sn) contacts are corrosion and wear-resistant, reducing fretting corrosion and ensuring reliable long-term performance.
- **Flexible Connectivity:** Our design along with the innovative Plug-in technology allows for easy wire connections from both sides, offering maximum design flexibility.
- **COB Pre-fixation:** The holder facilitates the pre-fixation of the COB, securely holding it in place. This feature allows for the holder to be flipped with the COB already attached, preventing it from falling.
- **Accessory Integration:** The holder features a locking interface for secure placement of reflector and lens accessories.
- **Clear Markings:** The holder features clear polarity markings, indicating precise connection points for the positive and negative wires.

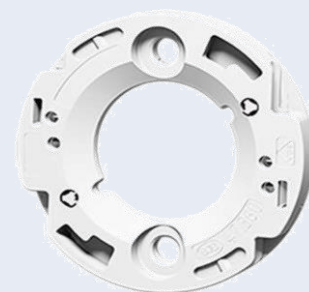
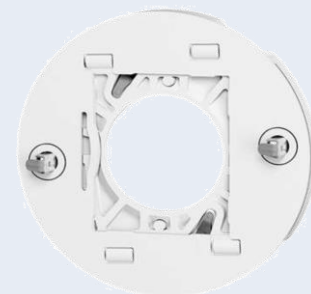

Accessories:

