

COB Connector Slim

47.360 COB Connector Slim Ø50 LED array 28 x 28

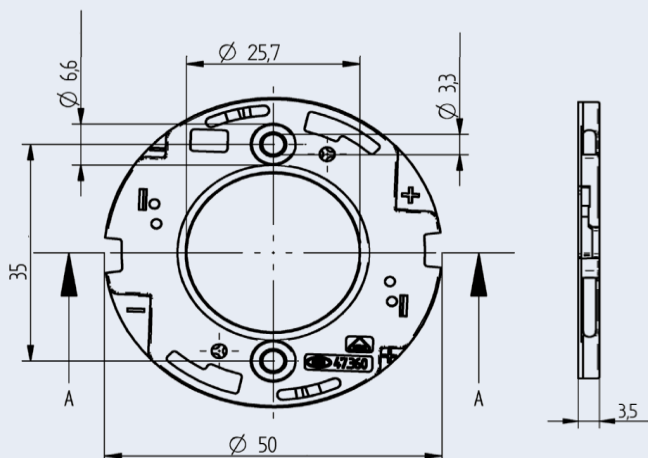

technology for light



Part no.

47.360.2105-0

- Compact Design
- High-Strength Housing
- Durable Contacts
- Flexible Connectivity
- COB Pre-fixation
- Accessory Integration
- Clear Markings

Polarity of LED must be observed

Specifications of LED manufacturer must be observed

cURus: For limited applications

Mechanical data		
Screw fixing	M 3	
Max. torque	0.5 Nm	
Alternative with P2F for blind holes	28.902.E102-0	
Integrated interface for reflectors	Yes	
Material data		
Material housing	PBT	
Material contacts	CuSn	
Weight	4.75 g	
Electrical data		
	VDE (EN60838-1)	UL (UL 8754)
Current rating	3 A	3 A
Voltage rating	150 Vdc	60 Vdc
Connection data		
Connection technology	push-in terminals	
Solid wires	0.35 - 0.5 mm ²	AWG 22 - 20
Stranded, tinned wires	0.35 - 0.5 mm ²	AWG 22 - 20
	max. 1.05 mm	
Strip length	8 +1 mm	
Country specific certificates		
VDE certificate	40047483	
UL file number	E345385	
Commercial data		
Packaging quantity	450	
Weight	4.5 g	
Environmental requirements		
Operating temperature range	-30 to +110°C	

Specification of LED manufacturer must be observed

In a series connection of LED modules, the air gap and creepage distances has to be sized that each modules cover the total voltage of the series connection

*Warranty conditions of BJB GmbH & Co. KG as stated as available via the Internet under <https://www.bjb.com/en/legal-information/general-terms-and-conditions/> are valid.

BJB Spotlight connection elements bring the components of an LED light engine together.

The Slim Gen 2 COB holder is engineered for exceptional durability, flexibility, and a straightforward, safe assembly process.

- **Compact Design:** At only 3.5mm (9/64 in) high, this holder helps minimize the overall height of a luminaire, making it ideal for sleek, low-profile lighting solutions.
- **High-Strength Housing:** Constructed from a high-strength Polybutylene Terephthalate (PBT) thermoplastic material, the housing offers excellent blue-light resistance, ensuring a long lifespan. The PBT mix also provides a highly reflective surface, enhancing the light engine's efficiency.
- **Durable Contacts:** The copper-tin (Cu-Sn) contacts are corrosion and wear-resistant, reducing fretting corrosion and ensuring reliable long-term performance.
- **Flexible Connectivity:** Our design along with the innovative Plug-in technology allows for easy wire connections from both sides, offering maximum design flexibility.
- **COB Pre-fixation:** The holder facilitates the pre-fixation of the COB, securely holding it in place. This feature allows for the holder to be flipped with the COB already attached, preventing it from falling.
- **Accessory Integration:** The holder features a locking interface for secure placement of reflector and lens accessories.
- **Clear Markings:** The holder features clear polarity markings, indicating precise connection points for the positive and negative wires.

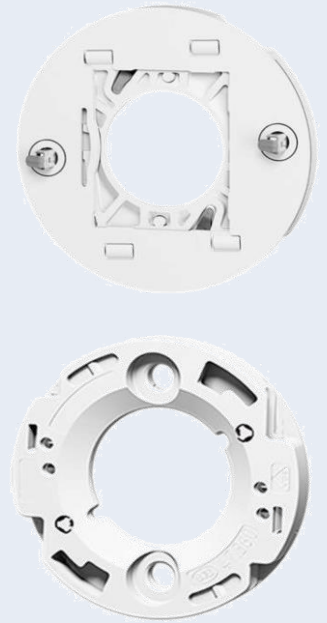

Accessories:

